

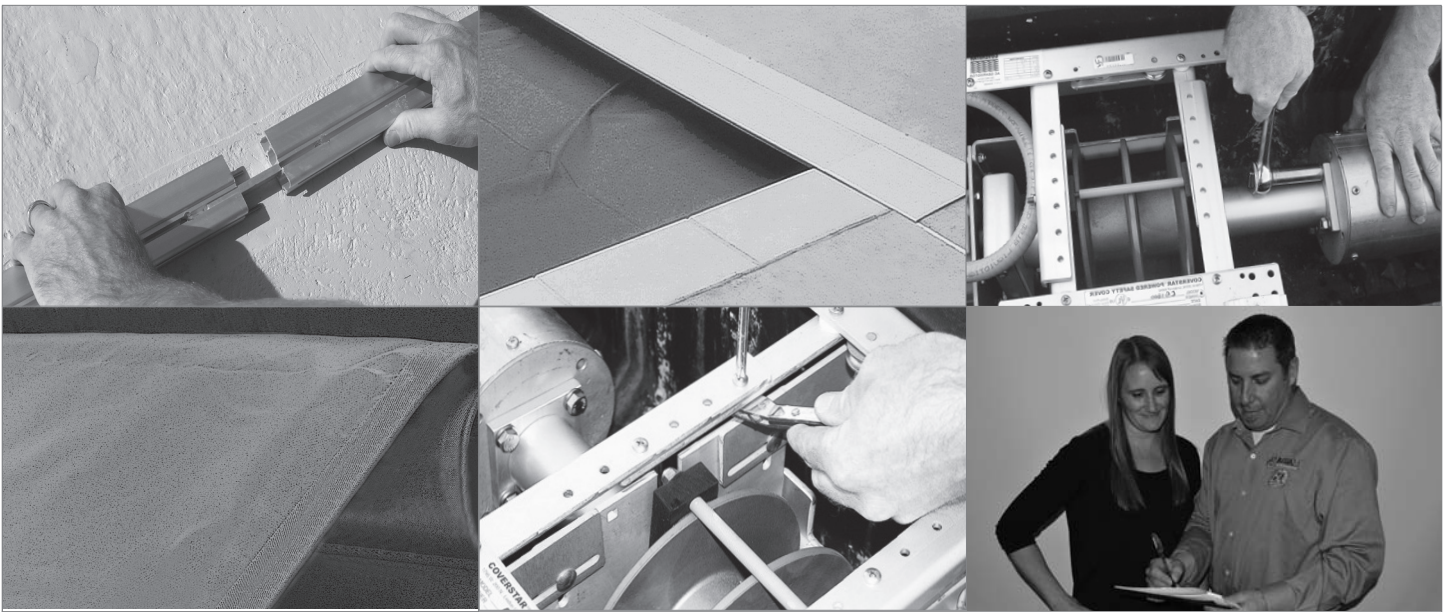

CS3000 Automatic Safety Pool Cover
Under Track System
with Aluminum Lid

INSTALLATION GUIDE



SECTIONS

Standard Under Track.....	4
Mechanism.....	6
Cover Fabric	10
Classic Aluminum Lid.....	16
Home Owner Checklist.....	18
Installation Check List	19

Tools Required

- | | |
|---|---|
| 1. Hammer drill or rotary hammer | 18. Crescent wrench |
| 2. Masonry drill bit 1/4" x 6" (1/4" x 12" bit) | 19. 100 & 25 foot tape measure |
| 3. Extension cords | 20. Chalk line (use white chalk) |
| 4. #2 and #3 Phillips & standard screw drivers | 21. Nut drivers - 5/16", 3/8", 7/16", 1/2" |
| 5. Ratchet with 5/16" - 3/4" sockets | 22. Chisel (wood & concrete) |
| 6. Hacksaw | 23. Scissors |
| 7. String line | 24. Wire strippers |
| 8. Utility knife | 25. Set of box/open end wrenches 5/16" - 3/4" |
| 9. Broom | 26. 6" level |
| 10. Hammer & rubber mallet | 27. Set of allen wrenches |
| 11. Pliers - standard, needle nose & channel lock | 28. Wire |
| 12. Files - round, triangular & flat | 29. Electrical tape |
| 13. Lighter | 30. Small sledge hammer |
| 14. Carpenter's square | 31. Vice grips |
| 15. 5/16" hex head driver bit with 12" extension | 32. #2 #3 Phillips drill bits |
| 16. Drill (cordless or corded) | 33. Pencil or marker |
| 17. Set of drill bits (1/4" down to 1/16") | 34. 6 - 8 clamps |

Optional Power tools

Skill saw with carbide tipped blade
Sawzall, Grinder, Angle drill

Parts Reference

Mechanism Components				Cover Fabric
Cover Track	Cover Lid	Lid Support Bracket	Cover Pump	
Parts List			Misc. Hardware	
<ol style="list-style-type: none"> 1. A0610 Motor & housing, standard 3 wire Bison motor 2. A0012 Mechanism RT or UT (Right) A0024 Mechanism RT or UT (Left) 3. M0305 Mechanism Mounting Foot 4. A0020 Non-motor end cone assembly 5. A0797 Tube insert for 6" tube 6. X0001 6" aluminum roll-up tube 7. A2359 Non-motor end assembly RT/UT (Right) A2358 Non-motor end assembly RT/UT (Left) 8. A0605 Key switch - Leviton assembly complete w/ light 9. A1100 Slider Assembly UT 403 & 801 for detachable ropes 10. A1688 Leading edge insert assembly UT 3" 11. X0021 Aluminum leading edge 12. Cover PowerFlex Rope - Lengths will vary with cover length) 14. A0614 403 Under Track, 21' 15. A0958 Pulley end cap assembly 403 & 801 UT 16. A1884 Guide feed 2 piece SS UT 17. X0004 Main Lid 18. X0121 Motor End lid 19. X0659 Non-motor end lid 20. X0943 8" Lid hinge 21. A1692 Standard cover lid bracket (set of 2) 22. E1130 Little Giant cover pump & instructions 23. A0407 UnderTrack retainer bracket set 	<ol style="list-style-type: none"> 24. M0104 Track splice UT 403 25. E1086 Bonding lug ka-6u (for 1 wire) 26. H0332 Screw PPSM 12 x 1-3/4 for UT STD (screw on track) 27. H0150 Parts kit cross brace joining screw 28. H0152 Screw PPMS 10-32 x 1/2 29. H0176 Nut nylock 10-32 30. H0075 Rope loop (black plastic) 31. H0310 Screw PPSM 10 x 1/2 32. H0313 Screw HHWSM tek 10 x 1/2 SS 33. H0324 Plastic anchor STD #12 34. H0331 Screw HHWSM 12 x 1-1/2 w/slot 35. H0294 Carriage bolt 1/4-20 x 3/4 36. H0096 Bolt HH 3/8-16 - 1-1/4 37. H0006 Split lock washer 3/8 38. E1098 Bonding wire 39. H9630 Spring pin for track alignment 40. H0276 Nut Nylock 1/4-20 41. H0130 Screw PFMS 10-32 x 1 42. H1099 Screw PPSM 10-32 1 3/4 			
<p>The above parts list is typical for most pools up to 20' x 40' and includes all parts necessary to install the Coverstar system, however, parts will vary for longer or wider pools and according to your specific order.</p>				

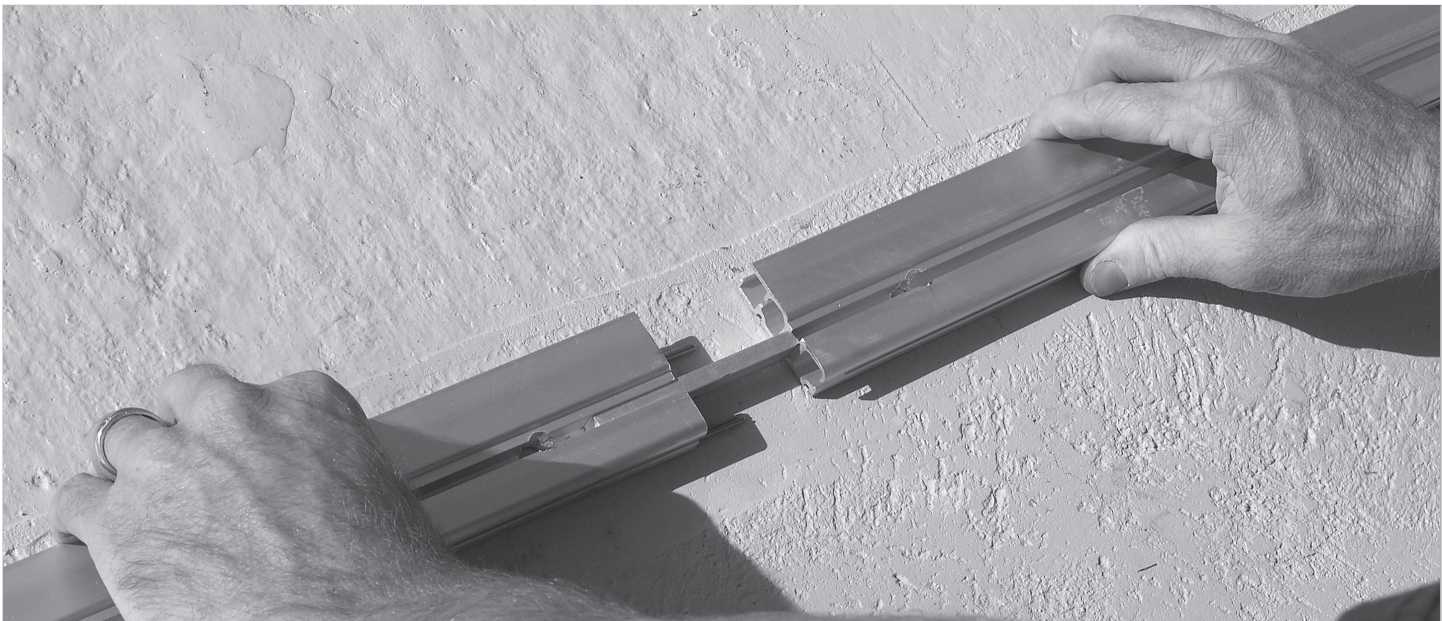

STANDARD UNDER TRACK

Step By Step Instructions	Page/Step
Track assembly	5/1
Mounting the track	
Standard under track mounting	5/6
Encapsulated under track mounting.....	5/7

Step By Step Instructions

Numbers in parenthesis refer to hardware shown on page 3.

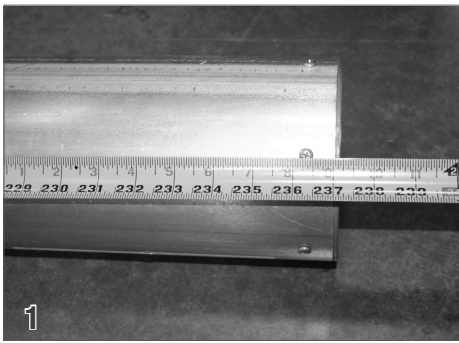

To determine if the cover system was ordered correctly for the pool, the length of the roll-up tube should be 3 inches shorter than the track space.

For example, for a 20 ft track space, the correct length of roll-up tube is 19 ft 9 in.



Cut the track so it will extend from the front edge of the coping at the far end of the pool to 1" past the inside of the housing if no encapsulation is being used. When encapsulation is used, it will extend one inch past the inside of the housing, with the track extending one inch past the end of the encapsulation.

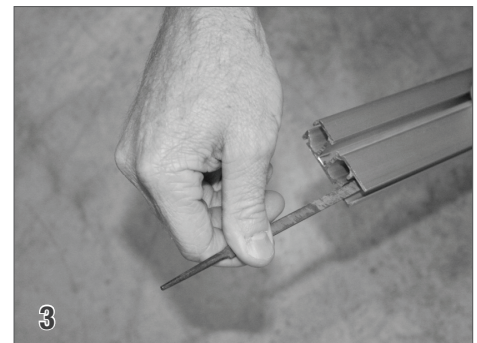

Before splicing the sections of track together, file all track ends thoroughly, rounding all edges and removing all burrs. This step is extremely important!

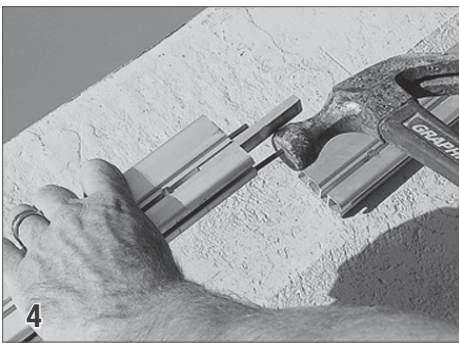

Tap the splice pins (39) into one end of the track and slide the center splice (24) into the center channel.



Lay the sections of track on the deck and tap them together using a rubber mallet so the center splice and splice pins interlock with each section of track. It's important that the splice is tight together so there is not a gap from one track to the next. Slide pulley end cap (15) into the end of the track at that is at the opposite end of the pool from the mechanism.



Standard Under Track

Clamp the track with pulley to underside of the coping flush with the coping face. (If water is in the pool, place the hammer drill with a 1/4" masonry (carbide-tipped) bit into a large bucket) Drill holes approx. 3" deep on a slight angle toward the pool wall. Remove clamps and track, then drive plastic anchors (33) into each hole. Finally, fasten the track to the underside of the coping with #12 screws (26).



Encapsulated Under Track (optional)

If encapsulation is being used, the track is normally installed during the cover installation. (See cover installation section page 11, step 9).

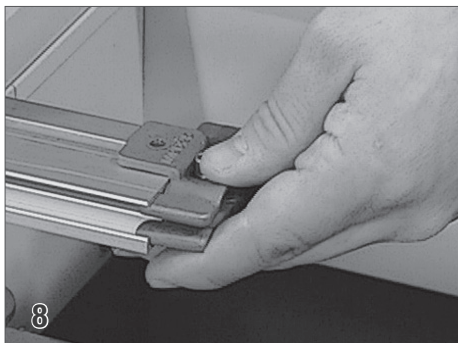

Using a 5/32" allen wrench, loosen the screw on the top of the guide feed (16). Insert the guide feed on the end of the track that will extend into the housing.

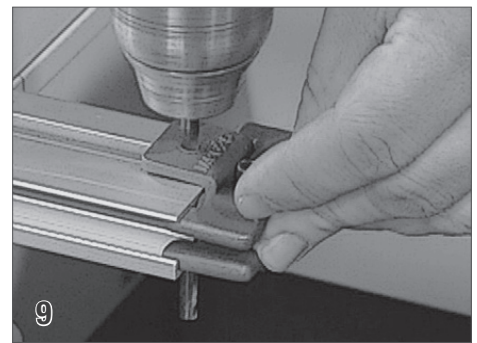

Holding the guide feed firmly, use a 6 inch 3/16" bit to drill through the hole in the track feed and through the track. Remove the guide feed. Do this for the track on both sides of the pool.

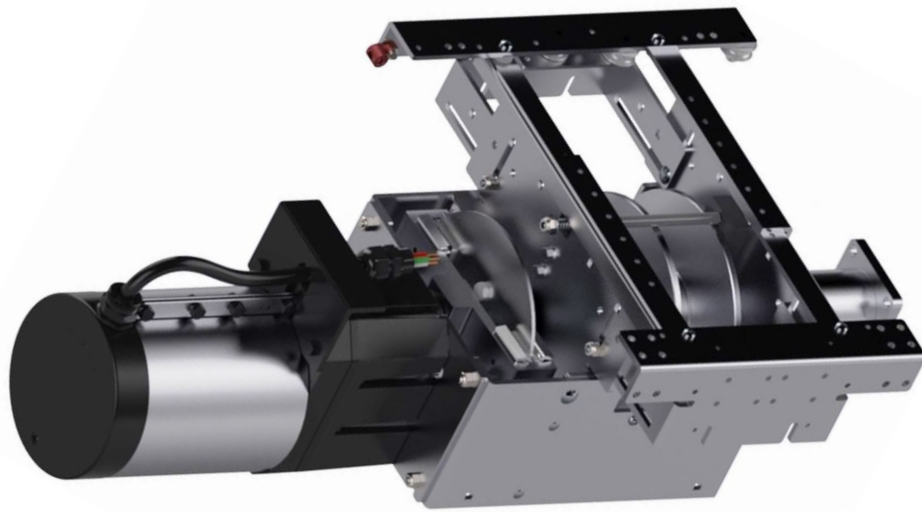

MECHANISM

Step By Step Instructions

Page/Step

Housing preparation.....	7/1
Connecting the roll-up tube.....	7/2
Adjusting the mechanism height.....	7/4
Positioning the roll-up tube/mechanism.....	7/7
Anchoring the mechanism.....	8/12
Extending the pulley brackets.....	8/13
Anchoring the pulley brackets.....	8/17
Wiring the electrical switch.....	9/19
Electrical wiring & bonding diagram.....	9/24

Step By Step Instructions

Numbers in parenthesis refer to hardware shown on page 3.



Housing Preparation

Use a garden hose to clean out the housing. During this process, make sure the water is draining from the housing. **It is critical that all cover housings have adequate drainage. If there is no drain or inadequate drainage in the cover housing, contact your Coverstar Representative.**

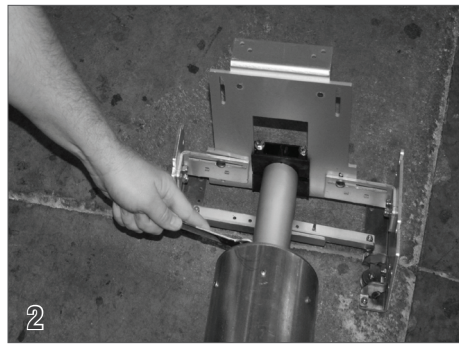

Connecting the Roll-up Tube

With the non-motor end turned upside down, attach the cone for the non-motor end to the roll-up tube using the 3/8" x 1-1/4" bolts (36) and lock washers (37) provided. Use a torque wrench to tighten the bolts to 180 inch pounds. Over tightening may cause damage to the threads and failure of the cover system.

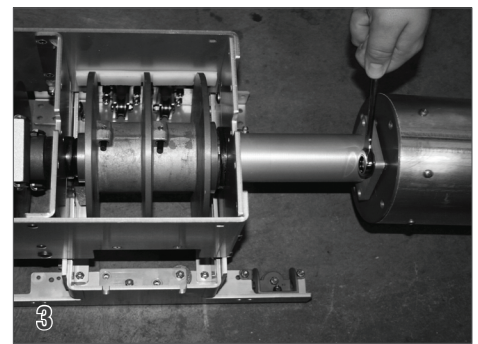

With the motor end turned upside down, attach the cone on the motor end using the same bolts (36) and washers (37). Tighten the bolts using a 9/16" wrench.



Adjusting Mechanism Height

Measure from the bottom of the housing to the top of the track or encapsulation. This is the installed height of the mechanism. Use this measurement to determine which holes to use when adding the mechanism feet. Install the roll-up tube as high as possible without rubbing on the lid brackets.

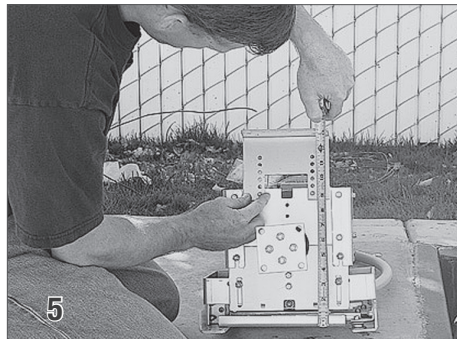

Position the mechanism with the pulley brackets on the bottom. Install the feet on the mechanism using the carriage bolts (35) and nylock nuts (40) provided. Install the feet so the top of the mechanism will be flush with the top of the encapsulation.

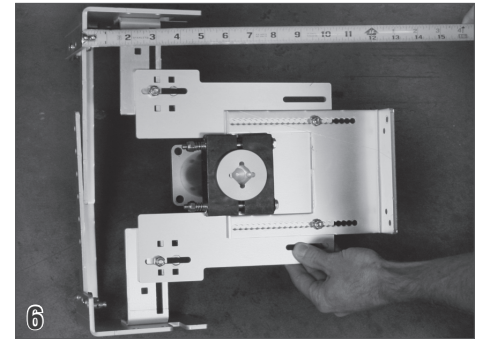

Install the feet on the non-motor end. The top of the pulley bracket should be flush with the top of the encapsulation.

Note: The height of the non-motor end might need to be adjusted after the mechanism has been placed in the housing.



Positioning the Mechanism

Lower the assembled mechanism and tube into the housing and place it roughly in the position that it will be anchored.



With the mechanism and tube assembled and set in place in the housing, check the roll-up tube for level. **This is crucial to proper operation of the cover.** Position a level across the housing. Measure from the roll-up tube to the bottom of the level on both the motor end and non-motor end of the mechanism. Adjust height of the non-motor end feet if needed to level the roll-up tube.

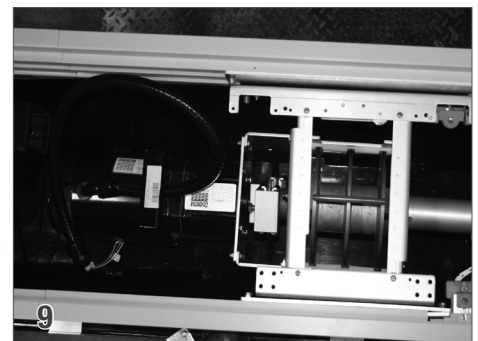

Position the mechanism in the housing so that the roll-up tube is centered in the housing front to back.

Note: If the cover housing isn't square to the pool, position the mechanism in the housing so it will be square to the cover track.

Step By Step Instructions

Numbers in parenthesis refer to hardware shown on page 3.

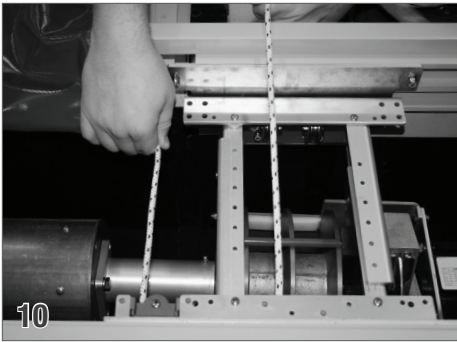

Align the mechanism on the motor side first by using a straight edge or a piece of rope and extending it from the back side of the cover track to the pulley to make sure the rope is running straight into pulley #1.

Tip: The pulley bracket on the front side of the cover housing should be 1 inch from outside of track.

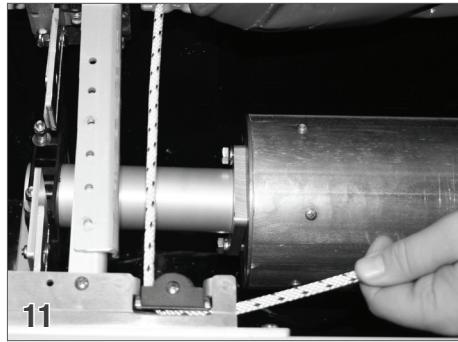

On the non-motor end, make sure the rope will travel straight from the track to the pulley. It is important that the roll-up tube be centered between the cover tracks.

Tip: The end of the roll-up tube should be 1-1/2 inches from the inside edge of the cover track.

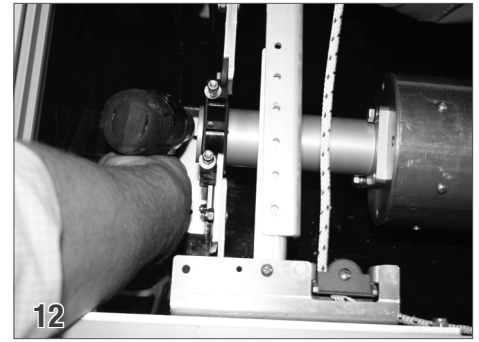

Anchoring the Mechanism

Center the motor end and non-motor end in the housing front to back. Anchor the non-motor and motor end feet into the housing using as many anchor points as possible.

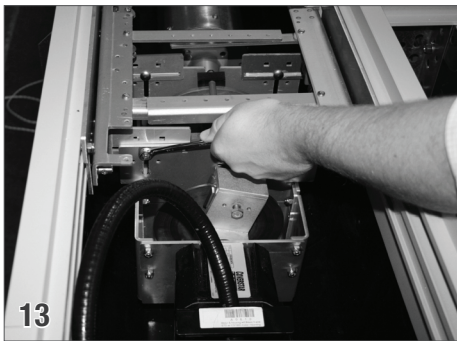

Extending the Pulley Brackets

Loosen the nuts in the four positions on the adjustable brackets of the mechanism. Spread the brackets outward against the walls of the housing.

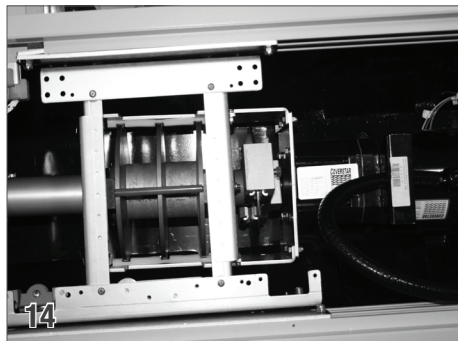

Raise the pulley brackets up so that the top of the bracket is even with the top of the encapsulation or guide. This insures the ropes will be level.

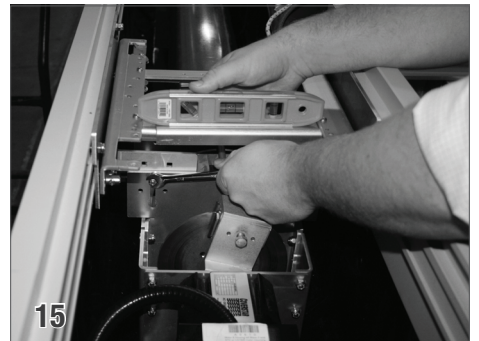

With the brackets in position, level the pulley brackets. Tighten the four nuts on the adjustable brackets.



Now loosen the bolts and spread the pulley brackets at the non-motor end making sure they are also level. Raise the pulley bracket so it is flush with the top of the encapsulation.

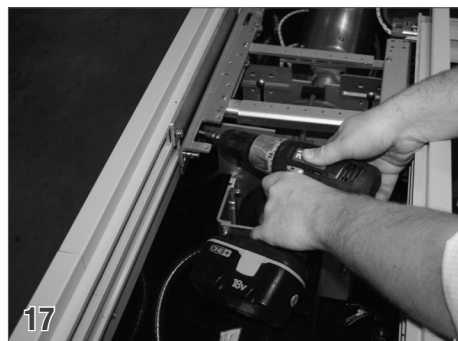

Anchoring the Pulley Brackets

Anchor the motor and non-motor end brackets into the housing in as many places as possible.

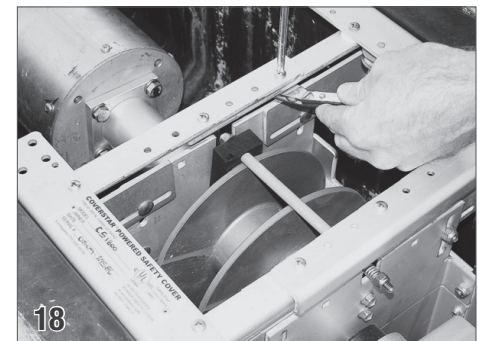

On the motor and non-motor side, use a 3/16" bit and drill through the cross braces. To secure, use the half inch screws (28) and nylock nuts (29) provided and bolt the cross braces together in two places on each cross bracket.

Step By Step Instructions

Numbers in parenthesis refer to hardware shown on page 3.



Wiring the Electrical Switch

Connect the electric switch by wiring the neutral wire from the power supply, the white wire from the motor and one of the wires from the indicator light together using a wire nut.

Note: Switch must be mounted in a position with a full view of the pool.

Connect the ground wires from the power supply and the motor together using a wire nut. Run a pig tail from this wire nut to the grounding lug on the switch.

Insert the hot wire from the power supply into terminal L1 on the back of the switch and tighten the screw. **Do not loosen the screws too much or the internal switch connections will be permanently lost.**



Attach the other leg from the indicator light and the **BLUE DIRECTIONAL WIRE** into terminal A1, and tighten the screw.

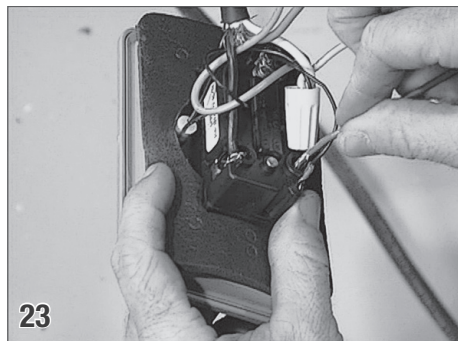

Insert the **RED DIRECTIONAL WIRE** into terminal B1, and tighten the screw.

Note: Reverse directional wires if cover runs opposite to the direction indicated on the switch.

24 Electrical Wiring & Bonding

The system must be bonded to meet the National Electrical Code. Bond both tracks to the mechanism by attaching a bonding lug to the guide feed screw and running a #8 solid copper bond wire to the mechanism. Bond the lid to the mechanism by drilling a hole in the lid at either end of the lid and attaching a bonding lug in each position and bonding it to the mechanism. All brackets and any other metal over 4" long should likewise be bonded to the mechanism. There should be a bond wire from the equipment pad inside the housing. Attach this bond wire to the mechanism to complete the bonding requirement. Note: Builder is responsible to bring proper electrical lines, conduit and bonding to the mechanism. Electrical wiring diagram and details are shown above with instructions on the right.

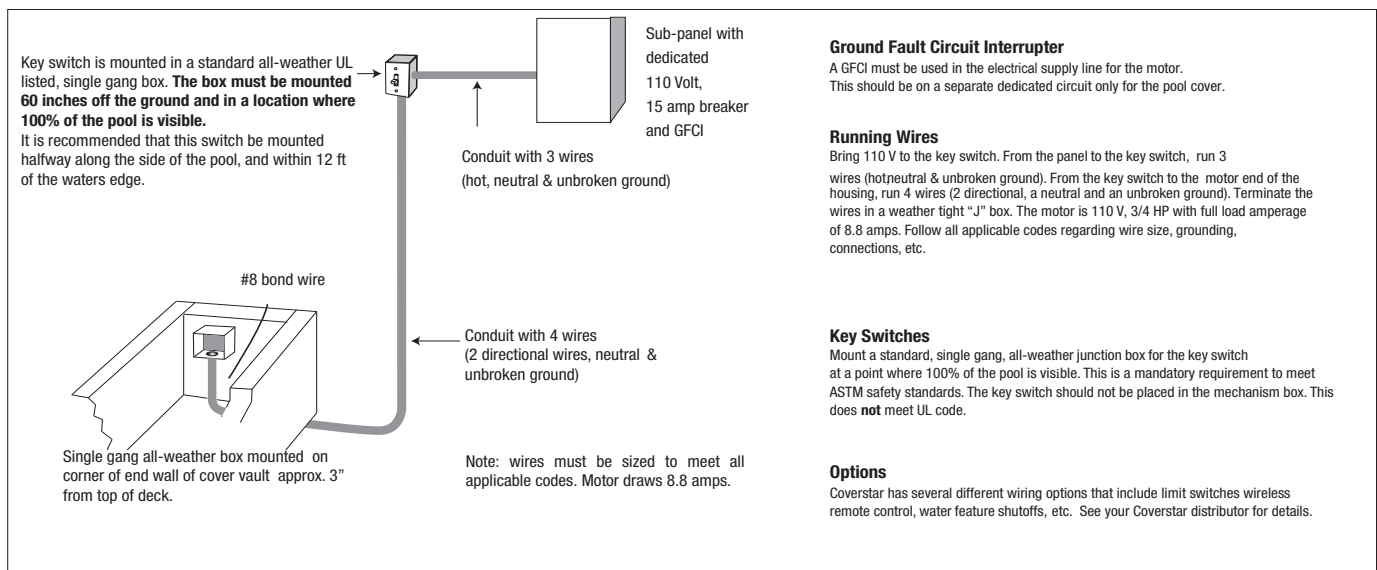

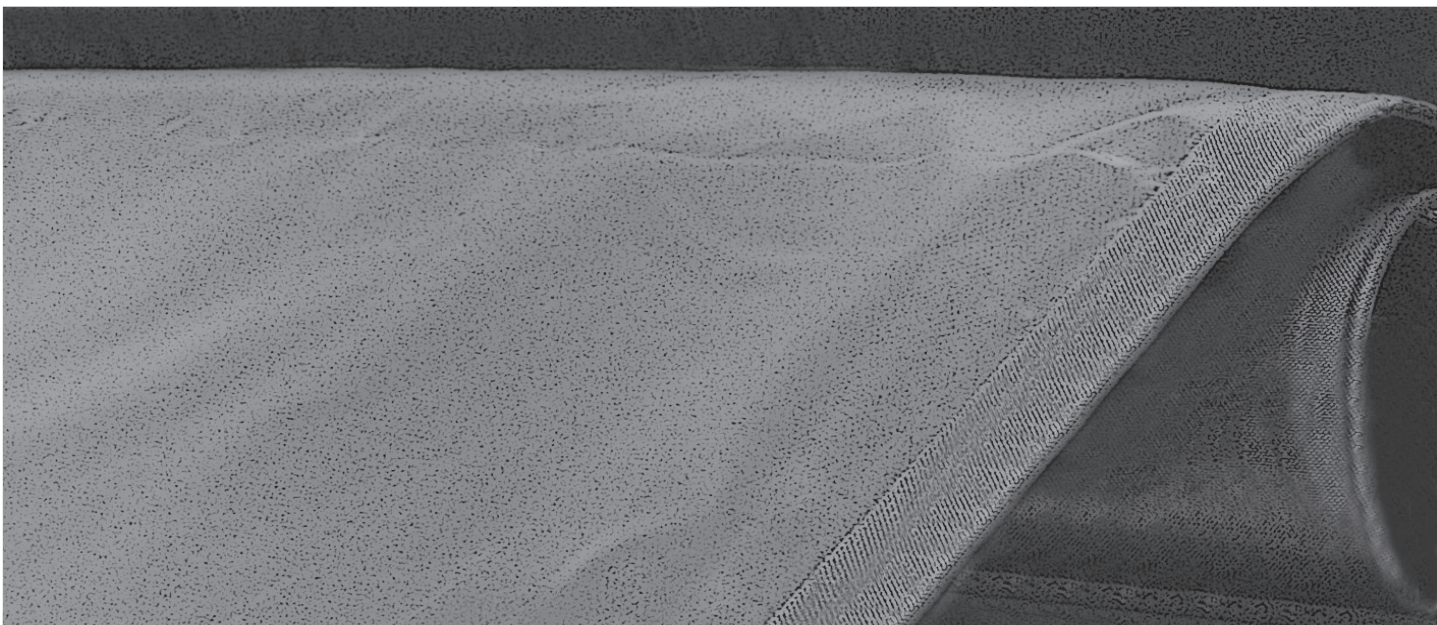

COVER FABRIC

Step by Step Instructions	Page/Step
Opening the cover package.....	11/1
Running ropes through the cover track.....	11/4
Alternate rope feed method.....	11/8
Installing the cover track	11/9
Routing the ropes	12/11
Attaching the cover leading edge	12/15
Track retainer method	13/21
Attaching the ropes to the reels	13/26
Running out the cover.....	14/30
Attaching the cover and bonding wire	14/31
Mechanism adjustments <i>(if needed only)</i>	
Rope adjustment.....	14/34
Torque limiter adjustment	15/37
Rope reel and non-motor end brake	15/39

Step By Step Instructions

Numbers in parenthesis refer to hardware shown on page 3.

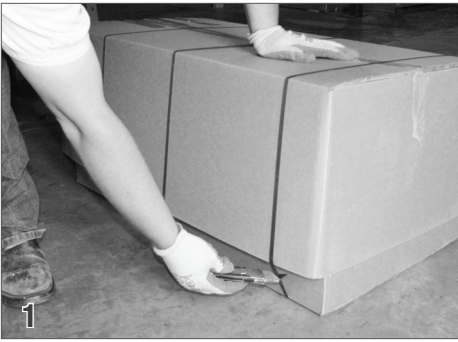

Opening the Cover

To open the cover box, cut the bands that hold the two halves of the box together. Never cut the top of the box open. Doing this could easily damage the cover inside. This kind of damage is not covered under the fabric warranty. With the bands cut, lift and remove the top box.



Standing behind the housing looking over the pool, unroll the cover from left to right.



Unwrap the ropes and run them through the tracks. There are two methods that can be used.



Running Ropes in the track

The preferred method of running the rope is to take a short length of the rope outside of the track and press it into the track on the water side.



Hold the rope outside the track to pull the rope down the length of the track toward the end of the pool.



Now, feed the rope through the pulley assembly. Insert the pulley into the end of the track.



Pull the rope down the back side of the track toward the cover housing.



Alternate Rope Feeding Method

Another common method of running rope is to pierce it with a small piece of wire. This wire then becomes the pulling handle as you feed the rope into the end of the track. This is especially useful if encapsulation isn't being used and the tracks are already installed.



Install Track in the Encapsulation

Starting at one end, lift the track so it will interlock with the encapsulation. Make sure the track extends 1" into the housing.

Step By Step Instructions

Numbers in parenthesis refer to hardware shown on page 3.



Insert and tap the spacer into place underneath the track along the entire length of the track. Do this along both sides of the pool. The spacer needs to end at the inside edge of the housing

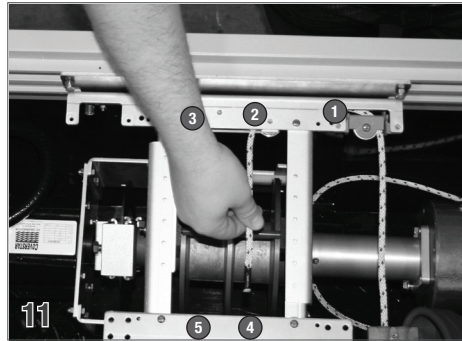

Routing the Ropes

Begin on the motor end. Pull the rope from the back channel of the track around pulleys #1 and #2. Continue pulling the rope to the front side of the mechanism. Run the rope around pulley #4 with the rope coming off the bottom of the pulley. Pull the slack out of the rope.

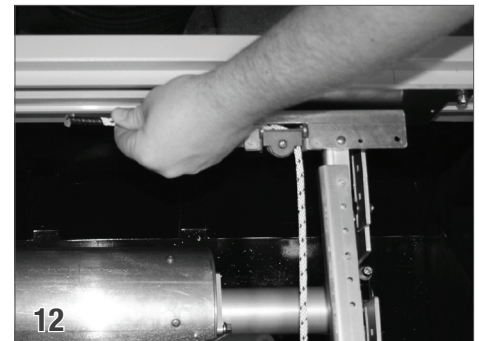

On the non-motor end, run the rope from the back channel of the track around the pulley.



Pull the rope along the back of the housing to the motor side.

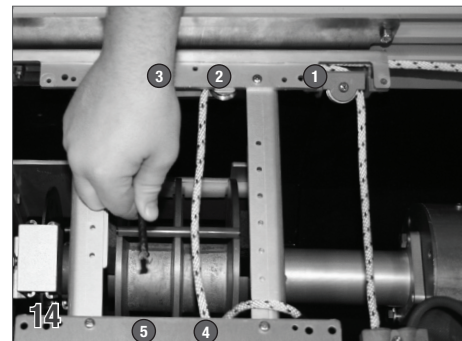

Run the non-motor end rope behind the motor end rope as it passes behind pulleys #1 and #2 and around pulley #3. Continue pulling the rope to the front side of the mechanism. Run the rope around pulley #5 with the rope coming off the bottom of the pulley. Pull all the excess rope through and lay it on the deck in front of the mechanism.



Attaching the Cover Leading Edge

Lay the front of the cover in front of the housing. Slide the leading edge through the loop on the front of the cover.



Place the nylon leading edge inserts (10) into the ends of the leading edge tube. Make sure they can slide freely inside the leading edge tube. The grooves in the leading edge insert should line up with the tongues in the leading edge tube.

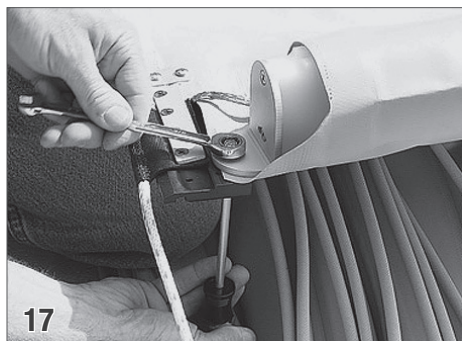

Secure the leading edge support bracket to the slider by placing the 10-32 X 1" (41) screw up through the slider, the hole in the front corner of the cover, and through the support bracket. Tighten completely using 10-32 nylock (29), then back the nut off 1/2 turn.



Pull the rope where it comes out of the track as you feed the slider and cover into the track a short distance. The guide feed should not be installed on the cover track at this point.



Place a guide feed over the end of the track, place a bonding lug (25) on top of the guide feed. Insert a 10-32 x 1-3/4" screw (42) through the lug and guide feed.



Use a 5/32" allen wrench to tighten the screw that connects the two sections of guide feed together.

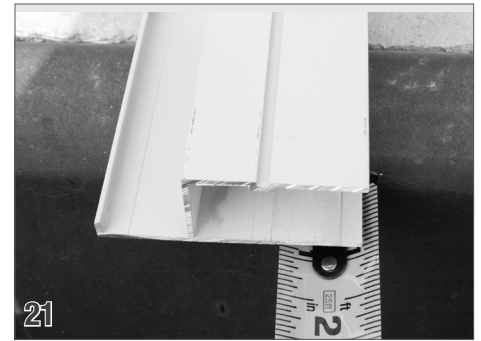

Encapsulation

When using encapsulation on the pool, extend it one inch into the cover housing. When cutting the cover track to length, extend it one inch past the encapsulation.



Drill through the center of the encapsulation and track. Insert a 10-32 x 1-3/4" screw (42) and nylock nut (29). This step is very important. This will prevent the track from sliding into the cover housing during the operation of the cover system. (If the encapsulation was cut flush to the inside of the housing, secure the track using a track retainer bracket (23)).



Run #8 copper bond wire (38) from the lug on each guide feed to the lugs on each mechanism end.



Connect the bonding wire that is attached to the front corner of the cover to the leading edge bar using a tek screw (32). Be sure the screw doesn't interfere with the leading edge insert.



Position the fabric on the leading edge so it is in line with the leading edge support bracket. Secure with a tek screw (32) on the back side of the leading edge. Be sure the screw does not interfere with the leading edge insert.



Attaching the Ropes to the Reels

Pull the cover back until the sliders are against the stops. Pull the ropes tight as they come off the pulleys on the mechanism to eliminate the slack in the rope.



While pulling both ropes tight, use a lighter or torch to burn the ends of the rope. Cut the ropes so they are the same length. These ropes should be at least 8 feet long. Use a lighter or torch to burn the ends of the rope to keep the rope from fraying. In some cases you will only need to cut one rope.

Step By Step Instructions

Numbers in parenthesis refer to hardware shown on page 3.

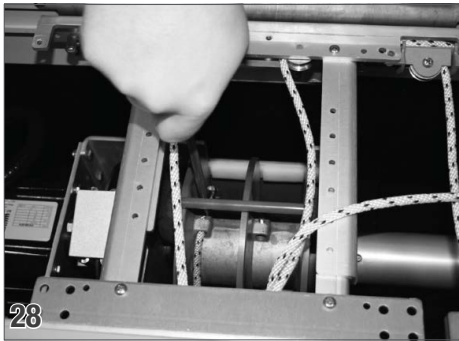

Bring the ropes back to the mechanism. Slide the rope through the rope lug on the rope reel. Secure the ropes to the reel by tightening down the set screws in each lug.

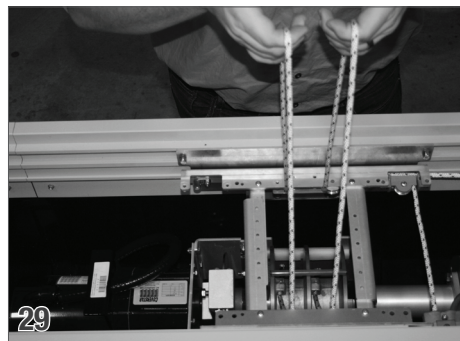

While holding the ropes over the mechanism, run the key switch in the cover position. The excess rope will be wrapped around the rope reel.



Running Out the Cover

Run the cover over the pool being careful to prevent it from binding in the guide feeds by lifting the cover if necessary.

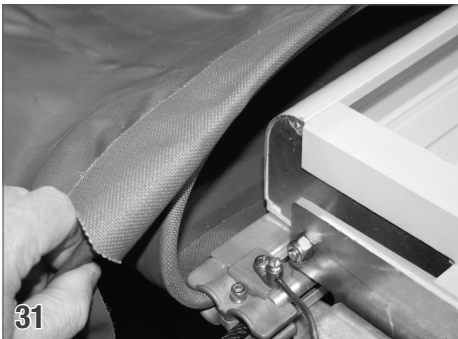

Attaching the Cover & Bonding

Wire Make sure the webbing continues straight as it travels from the track to the roll-up tube. Attach the cover to the roll-up tube using tek screws (32). The first screw on each end of the tube needs to be 3 inches from the end of the tube. As the cover rolls up on the tube, the webbing should roll up completely off the tube.



Lay the bond wire on top of the cover fabric. Secure it to the roll-up tube using a tek screw (32). Distribute the slack of the cover evenly between each screw across the length of the tube. Secure the cover to the roll-up tube using tek screws (32) every 2-3 feet. When attaching the cover to the tube, **do not use folds or pleats.**



Run the key switch in the uncover position to roll the cover up on the roll-up tube. Check the cover to be sure it rolls up evenly. Run the cover 6-10 times to make sure it opens and closes evenly. The cover fabric installation is now complete.

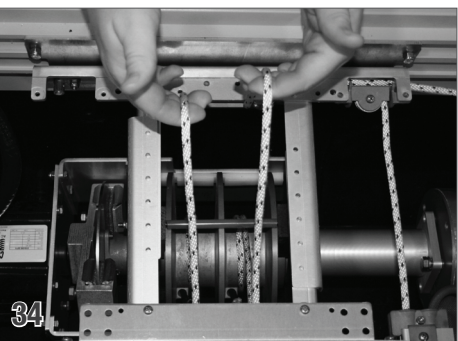

Adjusting the Ropes

When closing the cover, if both sides of the cover don't close squarely, one of the ropes may need to be adjusted. To adjust the rope, open the cover all the way. Pull the excess rope off the rope reel.

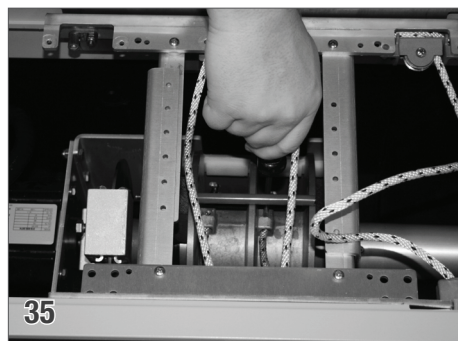

If one of the ropes is longer than the other rope, loosen the set screw that secures the rope to the rope reel lug. Shorten this rope until it is the same length as the other rope. Re-attach the rope to the rope reel.

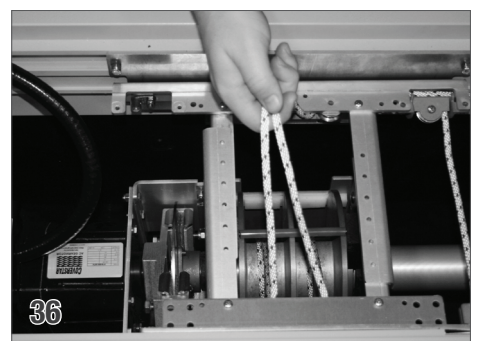

If both ropes are the same length, and the cover doesn't close squarely, shorten the rope for the side of the cover that doesn't close all the way. The amount that the rope is shortened is equal to the amount distance that the cover needed to travel to close all the way. While holding the rope, run the switch in the cover position.

Step By Step Instructions

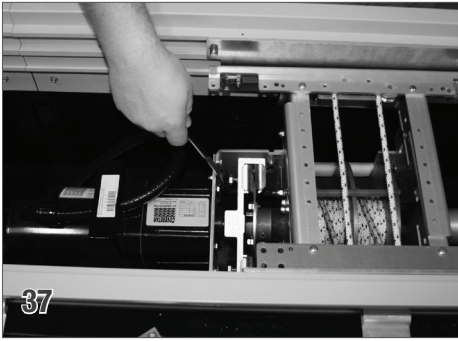

Adjusting the Torque Limiter

The Aluminum automatic cover system is equipped with a torque limiter that helps prevent damage to the mechanism. Only if the motorized mechanism does not extend or retract the cover will you need to adjust the torque limiter.

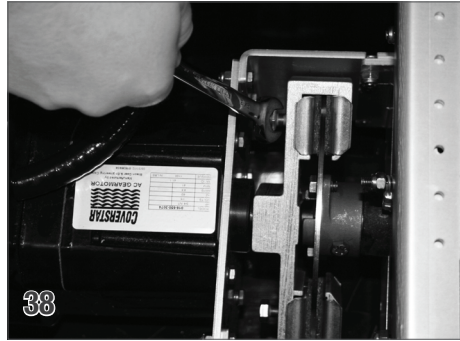

To adjust the torque limiter, use a 9/16" wrench to tighten the first torque limiter bolt 1/2 turn. Run the cover.

If further adjustment is needed, rotate the torque limiter brake arm to position the second brake bolt and tighten the second brake bolt 1/2 turn.

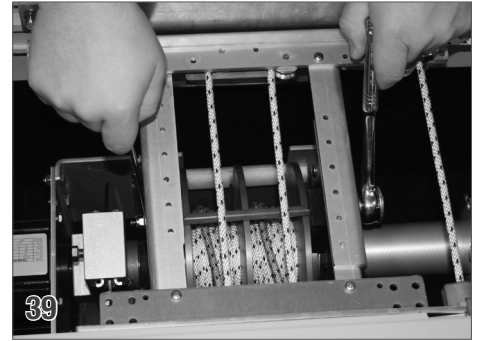

Adjusting the Brakes

The mechanism is equipped with two brakes; one on the rope reel, and one for the roll-up tube of the mechanism. The brakes are preset at the factory and should work properly.

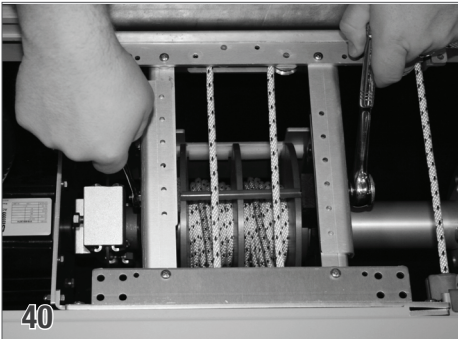

Rope Reel Brake

The rope reel brake should be tight enough to prevent the ropes from free spinning off the reel while the cover is opening. If you need to adjust the brakes, use two 7/16" wrenches or sockets to adjust the tension on the rope reel.



Roll-up Tube Brake

The roll-up tube brake should be tight enough to prevent the cover from rolling off the tube faster than it is being pulled into the track. To adjust this brake, use two 7/16" wrenches and tightening or loosening the thru bolts in the brake block.

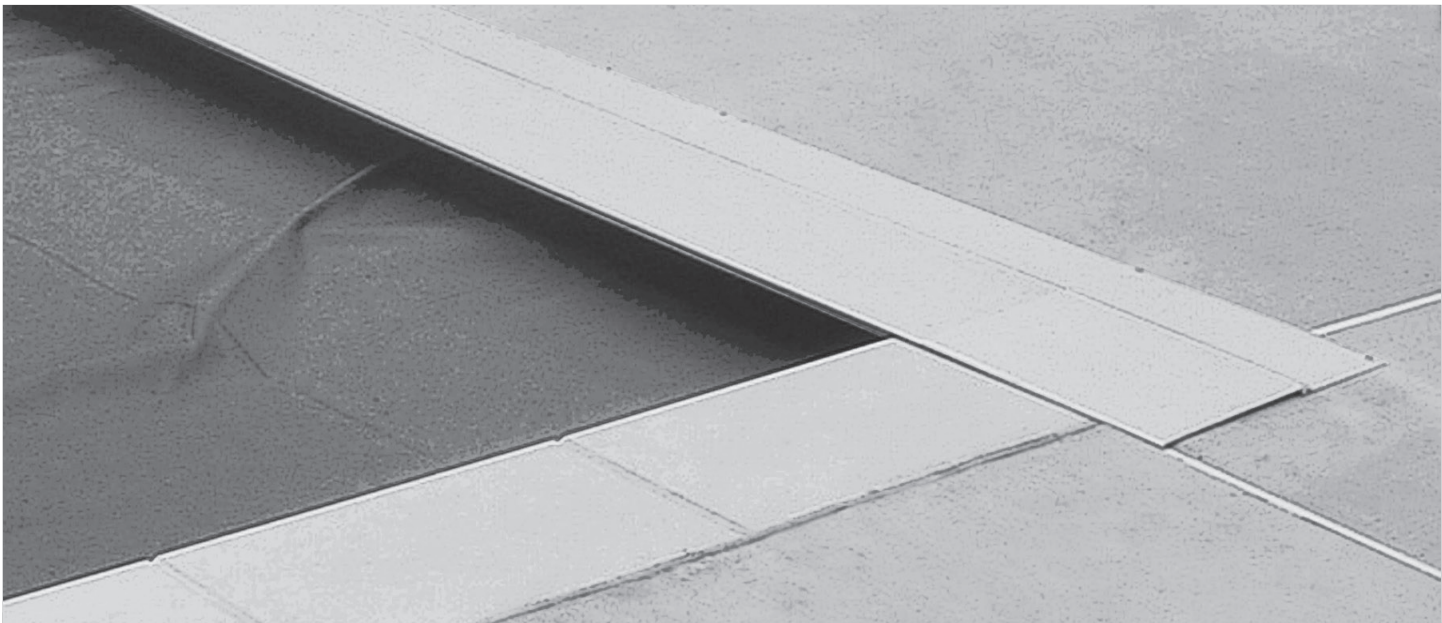

CLASSIC ALUMINUM LID

Step By Step Instructions	Page/Step
Installing the lid brackets	17/1
Assembling the aluminum lid	17/4
Attaching the lid to the deck	17/7



Installing the Lid Brackets

Hold the bracket against the back wall of the housing so it is flush with the top of the deck. Use a 1/4" masonry bit and drill through the holes in the bracket into the back of the housing. Be sure to drill the holes at least 3" deep. Tip: Drill one hole and insert the anchor. Level the bracket and insert a screw. This will help hold the bracket while the remaining holes are drilled.



Remove the bracket and insert plastic anchors in each of the holes. Tap the anchors (33) with a hammer so they are in the hole completely.



Secure the brackets to the back wall of the housing using #12 x 1-1/2" hex head (34) screws. Mount a rope loop (30) on one screw of each of the brackets. This will keep the rope running straight along the back of the housing.



Assembling the Aluminum Lid

The aluminum lid will come with each section cut to length. Assemble the lid by sliding the hinge onto the main section of lid.



Slide the motor and non-motor lid ends onto the hinge.



Position the lid over the top of the housing. The motor end and non-motor ends should extend past the cover housing 1-2". If they extend more and do not lay flat on the deck, it may be necessary to cut the lids. Mark the lid with a square at the 1" overlap point and cut it to length with a hacksaw or power saw with carbide tipped blade.



Attaching the Lid to the Deck

Drill through the lid hinge along the back edge every 2-3 feet using a 1/4" drill bit. Then, drill through these holes and into the concrete deck using a 1/4" masonry bit. Remove concrete dust from the holes.



Insert plastic anchors (33) into the holes and tap with a hammer so they are flush with the deck. Fasten the lid to the deck with #12 pan head screws (26).



Measure across the hinge to evenly space the screws. Continue drilling and anchoring the hinge in this manner until the entire lid is attached to the deck. The safety pool cover installation is now complete. Now instruct the home owner using the home owner's guide and the checklist on the next page.



HOME OWNER CHECKLIST

After the cover system is installed, it is critically important to instruct the home owner on how to operate the cover system safely and do routine maintenance. Use the following check list and the Use & Care Guide as your primary instruction source.

Use & Care Guide Page

- How to use the cover pump4
- How to uncover and cover the pool 6-7
- Warn about standing water on the cover 4
- Who is authorized to operate the cover system 6
- Pool chemicals and cover life..... 8
- Proper maintenance and care of the cover system ... 8-9
- Inform the customer on pool safetyBack cover

Installation Check List

Tracks

- Does the track space measurement match how the cover system was ordered?
- All track ends filed. This is extremely important.
- Cover goes through the track joints smoothly.
- All track screws are tight and flush.
- Pulleys are flush against the end of the track.
- The guide feeds are snug against the track.
- Guide feeds bolted in and are tight.
- Stops installed.
- Alignment pins and splices used when joining the tracks, even in encapsulation.

Mechanism

- Mechanism installed level in the box.
- Roll-up tube level in cover box.
- Tube centered between the tracks.
- Enough clearance top, bottom, sides for the fabric. No rubbing of webbing on sides or bottom of box.
- Tube at the right height? The ideal location is to install the cover in the box so that the cover is coming off at as small an angle as possible. This reduces stress on the mechanism and reduces wear on cover tracks at the end of the track.
- Tube either centered in the box or positioned slightly more towards the back of the box, so that the cover is unlikely to rub on front of the box.
- System mounted at right angle to the track.
- Ropes coming back straight out of the track. An excessive angle will cause wear on the cover tracks at the end of the track.
- Ropes are not rubbing on any brackets or the deck.
- Ropes are run correctly.
- 8 feet of rope left on rope reel.
- System bonded according to electrical code. Cover bonded to leading edge and roll-up tube.
- Make sure there is adequate drainage from the cover box.

Cover

- Fabric pinned to the roll-up tube without pinned folds.
- Cover runs smoothly.
- Cover properly aligned when it closes or retracts. Note: An inch or two out of square is not uncommon and is not a concern as it will not affect the operation of the cover. Because of the size of the fabric roll and changes in operating conditions the cover may vary slightly in alignment as it is run.
- The leading edge inserts move in and out freely the whole length of the pool.
- Fabric is pinned to the leading edge flush with the ends of the tube.
- Cover not rubbing in the cover box as it rolls up.

Cover Lid

- All sharp edges have been filed.
- All areas where the lid is not flat on the deck have been screwed down to eliminate any potential hazards.
- There is enough clearance between the lid brackets and the cover to avoid rubbing.

Misc.

- Key switch is in full view of the pool.
- Cover pump tested by putting it in the water and operate it in front of homeowner.
- The cover box is clean and clear of debris so that the drains are not easily clogged.
- Pool area cleaned up.
- Homeowner has been instructed on the operation of the automatic safety cover system.