

Box Perimeter and Lid Forming Installation Instructions

Box Perimeter Forming Kit Parts

The box perimeter and lid forming kits are available to match the one piece Inclined and one piece cantilever coping form shapes. When ordering these kits, a reusable lid forming kit and a consumable kit will be needed. The consumable kit includes the box perimeter encapsulation and the lid brackets. The lid brackets are available with either a set height lid bracket hook or an adjustable height lid bracket.

- | | |
|--|--|
| 1. Vertical Form Transition to Coping | 9. Box Spanning Bracket* |
| 2. Vertical Form Corner | 10. Coping Form Splice |
| 3. Box Encapsulation | 11. Multi Form Spacer |
| 4. Box Vertical Extrusion 6" | 12. Corner Joining Bracket |
| 5. Adjustable Walk-on Lid Bracket Arm | 13. Sliding Anchor |
| 6. Lid Support Hook | 14. Adjustable Lid Bracket Base |
| 7. Lid Support Hook for Motor & Non-Motor Ends | 15. Adjustable Lid Support Hook |
| 8. Box Form Encapsulation Mounting Bracket* | 16. Adjustable Lid Bracket for Motor End and Non-Motor End |

*Not pictured in diagram below

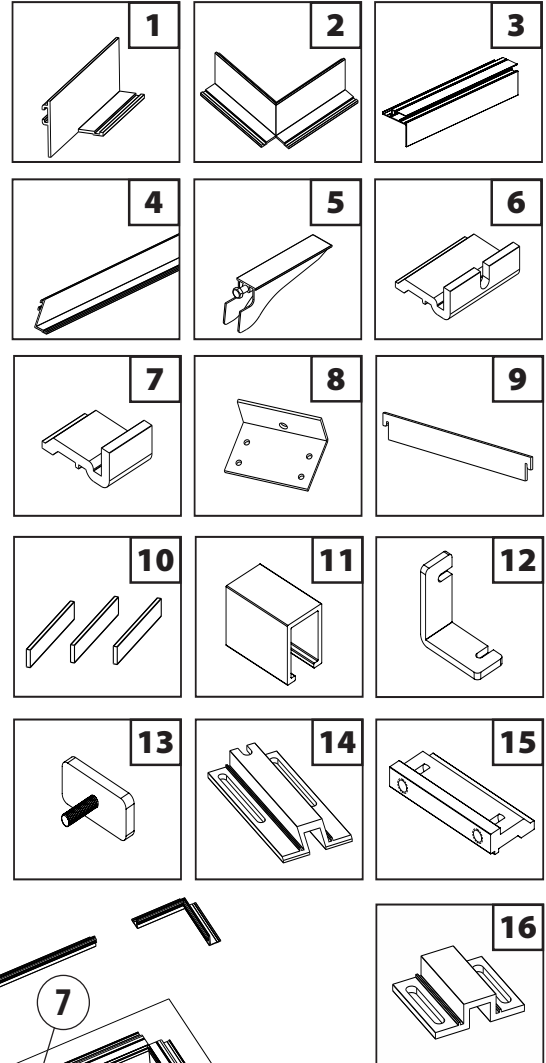

NOTICE

The following instructions are for a basic installation of the box perimeter and lid forming system. Your installation will vary by box width, encapsulation type and coping style.

Please watch carefully for instructions pertaining to the specific system you are installing.

Box Perimeter Diagram (exploded view)

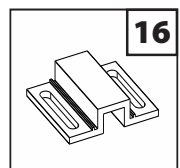
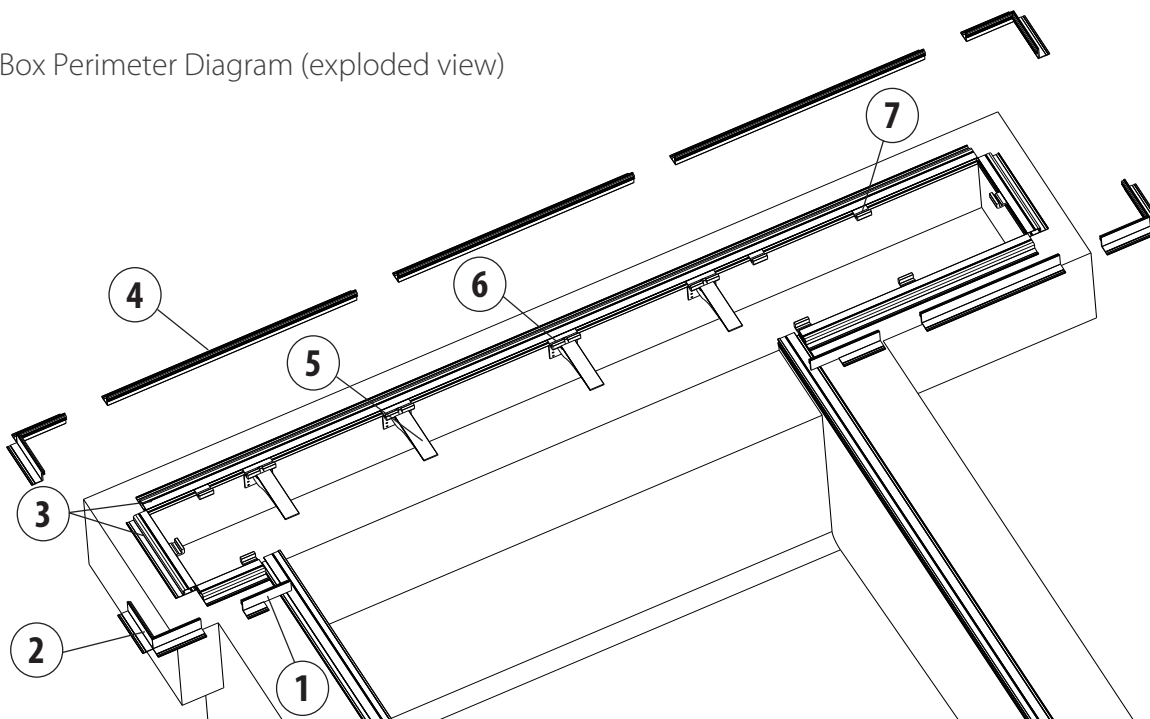

Drawings not to scale

Box Perimeter Instructions

Tools Required

Framer's square, cordless drill, duct tape, form release product

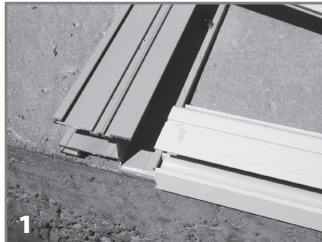

1
If you are using encapsulation around the perimeter of the pool, you should install the encapsulation first in order to allow the box perimeter encapsulation to stop against the edge of the pool encapsulation.



2
Use a framer's square to ensure that the corners are perfectly square before screwing down the box forming encapsulation.



3
Mounting brackets are provided to create a larger mounting surface in cases where the housing perimeter is smaller than 2-1/2" across the top. (Great for wooden boxes).



4
Use the spanning brackets across the motor and non-motor ends to ensure that you maintain the proper spacing from one side to the other.



5
Fasten the encapsulation around the perimeter of the housing using the ten screws provided. Remove the spanning brackets.

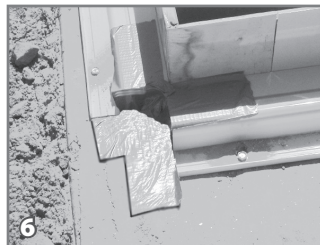

6
If the encapsulation is cut square on the corners, cover the openings with duct tape.

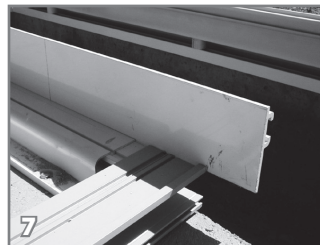

7
Install the vertical transition forms into the encapsulation on each corner where the housing transitions to the coping.

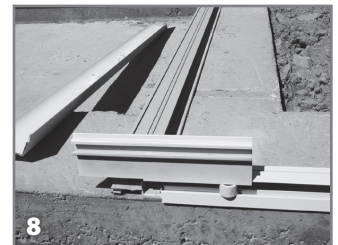

8
Place a spacer under the form to lock it in place.



9
Form the box ends by installing two corner forms on each end. Slide a splice into the channel and then slide it across the joint when it is in place.



10
Use straight lengths of the vertical form to complete the forming of the perimeter of the housing.

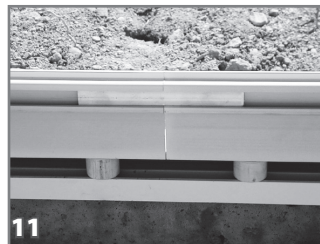

11
Slide splices into each length next to each joint and slide them over to create a smooth splice between lengths of the form.



12
Use the spacers to lock the form in place.



13
Cover open areas with duct tape so the concrete does not seep in.



14
Spray a form release product, such as cooking spray, onto the reusable forms. This will allow for easy stripping. Pour the housing perimeter.



15
Strip forms by removing splices and spacers. Be sure to clean forms thoroughly for next use.

Lid Forming Kit Parts

The reusable lid forming kit includes 9 standard lid forming trays, 2 trays that will form the transition lid sections for the motor end and non-motor ends, one tray that will form the motor end lid with vertical forms, and one adjustable tray that will allow a lid section to be poured at a custom length.

- | | |
|---|------------------------------------|
| 17. Thumb Screw | 23. Lid Forming Retainer Bracket |
| 18. Box Form Vertical Extrusion 28" | 24. Box Form Shape Extrusion 28" |
| 19. Brass Nut | 25. Lid Forming Transition Bracket |
| 20. Lid Forming Tray with Weight Saver | 26. Sliding Anchor |
| 21. Lid Forming Tray with Flat Bottom | 27. Adjustable Divider Assembly |
| 22. Lid Forming Retainer Bracket with Shape | |

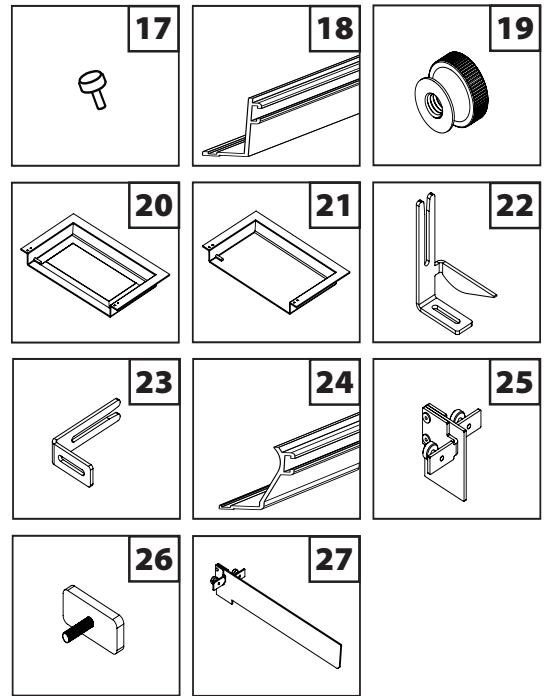

Drawings not to scale

Lid Forming Diagrams

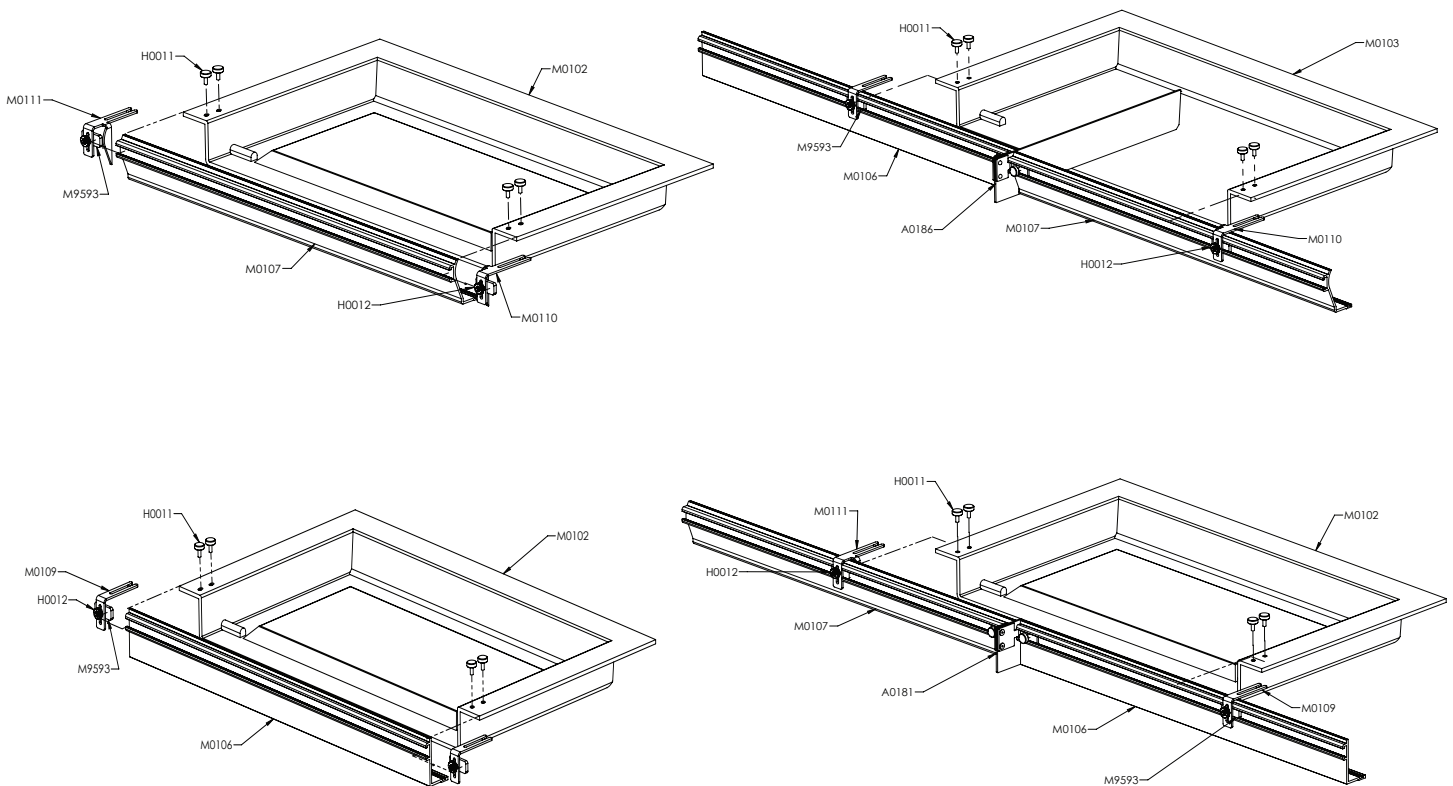

Lid Forming Instructions

Tools Required

Form release spray, concrete shaping tools

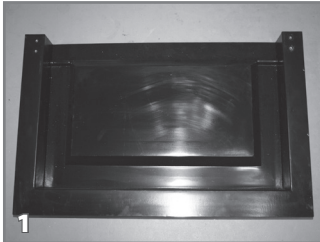

1 Place the lid forming trays on a flat, level surface.

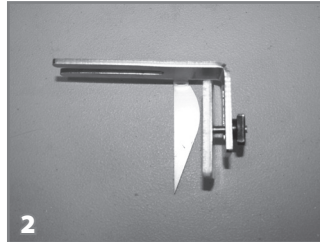

2 Insert the pem stud on the sliding anchors through the slot on the lid forming retainer brackets. Thread the brass nuts loosely on the pem studs.

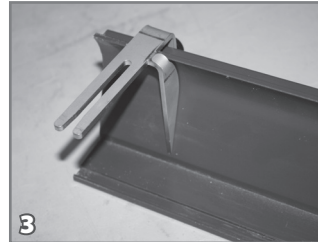

3 The lid forming retainer bracket comes in two options, one with a shape piece for the inclined or cantilever shapes, and one without the shape piece that is used with the vertical form.

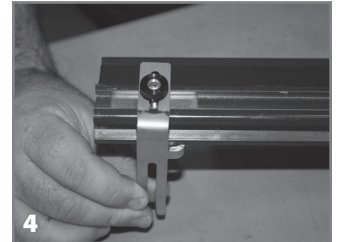

4 Place the slide anchors into the splice channel on the back side of the form.



5 Loosely thread the thumb screws into the t nuts that are pressed into the lid form tray.

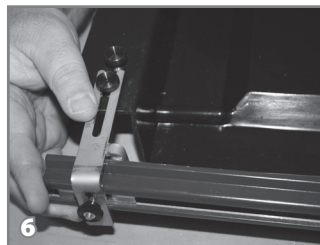

6 Attach the lid form to the lid forming tray by sliding the slot in the retainer bracket under the thumb screws in the tray. Slide the form from side to side to center it on the form. Tighten the thumb screws in the tray and the brass nuts on the back side of the retainer brackets.

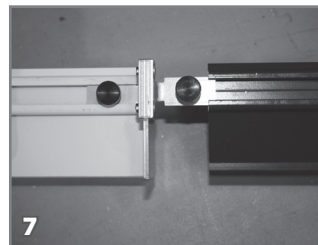

7 To assemble the trays with the transition forms or the adjustable divider, place the transition bracket or adjustable divider bracket between a vertical form and a shape form. Tighten the brass nuts on the backside of the brackets.

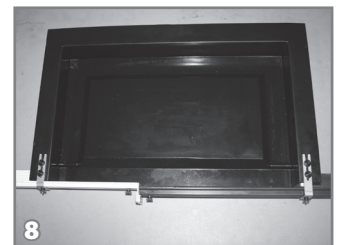

8 Adjust the transition forms side to side to create the size needed for the motor side and non motor side.

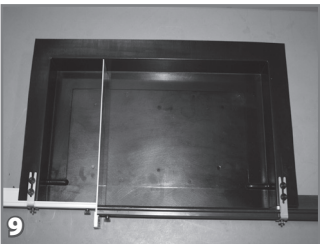

9 Slide the adjustable divider bracket from side to side to create the size of lid section needed.

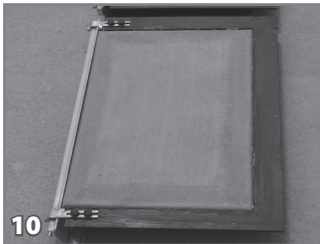

10 With the trays assembled, apply a concrete release agent to the trays and forms. Pour the concrete and vibrate the forms to remove air pockets.

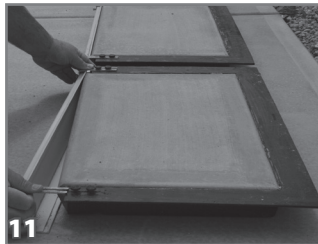

11 As the concrete sets, the front form can be removed to expose the front of the lid for texturing, staining, troweling, etc.

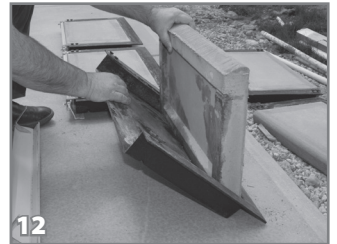

12 After the concrete is completely set, remove each lid section from the tray. Clean the trays and form pieces so they are ready for their next use.



13 The trays were designed so the middle section of the lid will be thinner to reduce the weight of the lid section.

Lid Installation Instructions

Tools Required

Tape measure, cordless drill, small level



1 Place the lid support hooks in the box encapsulation at the motor end and non-motor ends. The lid support hooks and brackets come in two options, one that has set height, and one that can adjust vertically to accommodate different lid thicknesses.



2 Place the lid bracket hooks into the box encapsulation. Slide the lid bracket arm over the slot in the hook. These lid brackets can slide side to side in the encapsulation to move them to the desired location.



3 Place a small level on the lid bracket arm. Adjust the bolt on the back side of the arm to level the bracket.



4 Place the motor end and non-motor end sections of lid on the lid support hooks and lid brackets.



5 When using the lid forming transition pieces, the lid section will run past the motor and non-motor ends of the cover housing.



6 The lid sections are formed to include a slot on the underside of each section. A screw can be attached to the lid bracket so the slot in the lid section will sit over it to prevent the lid section from sliding.

Measure the distance from the back of the cover box to the slot in the concrete lid.



7 Drill a hole on each side of the lid bracket that will line up with the slot in the lid section.

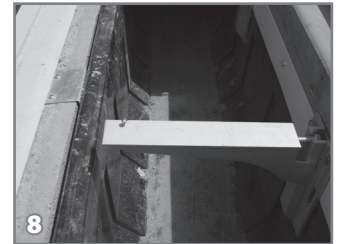

8 Place a screw into each hole with a nut on the underside of the bracket. It is important that this screw not be too long that it will hang down and damage the cover.



9 Place the concrete lid section in place with the slot fitting over the screw. Place the remaining lid sections on the lid brackets. Adjust the brackets as needed to support and level the concrete lid.

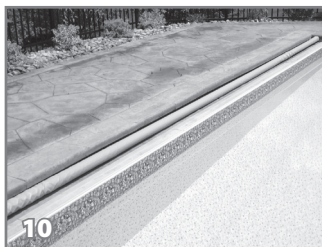

10 The box and lid forming system is now complete.

Coping Form Options

One-Piece Deck Form Shapes

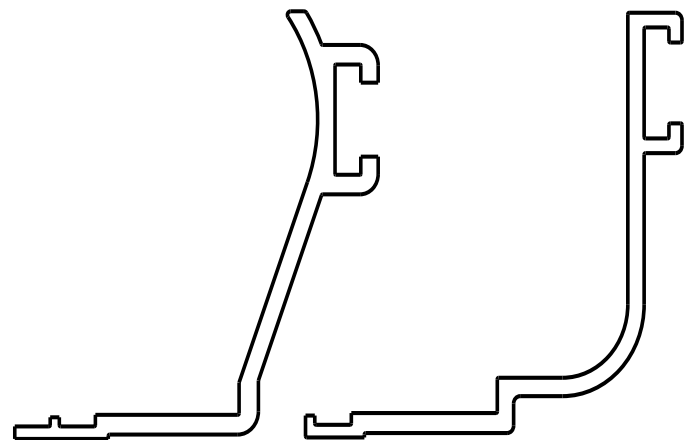

Inclined Form
2-1/2" Deck Height

Cantilever Form
2-1/2" Deck Height